



# TECNOGEN

**CUMMINS GENSETS SERIES**

**DATA SHEET AC550**

**420 KW STAND BY**

**400 KW PRIME**



**TECNO GENERACION SAC**

**Lima - Perú**

## General Performance Data

Prime Power	500KVA/400KW	Engine	Brand	Cummins
Stand by Power	525KVA/420KW		Model	QSZ13-G3
Frequency/Speed	60Hz/1800rpm	Control module	Deepeat 6120	
Rated Power Factor(cosφ)	0.8	Rated Current	1312A	
Standard Voltage	220V	Capacity of Breaker	1600A	
Phases	3	Starting Voltage	DC24V	

## Fuel consumption

Rated output	Fuel consumption rate	
100%Standby	204g/KW.h	118.6L/h
100%Prime	199g/KW.h	104.1L/h
75%Prime	193g/KW.h	75.7L/h
50%Prime	194g/KW.h	50.8L/h
25%Prime	214g/KW.h	28.0L/h

## Standards followed

ISO9001	ISO14001
ISO8528	ISO12100
ISO13849	EN12601
GB12786	GB/T2820
IEC60034	IEC60204
CE	RETIE

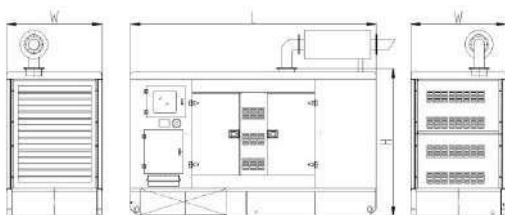
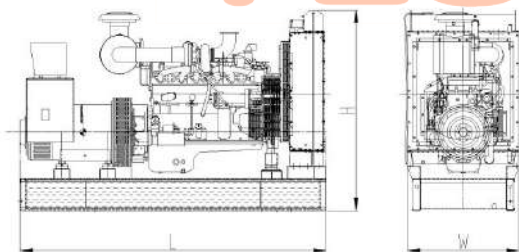

## Dimensions and Weights

Type	Open	Silent
Length(mm)	3000	3850
Width(mm)	1360	1700
Height(mm)	2165	2230
Weight(kg)	3250	4100
Base fuel tank volume (L)	850	850

## Engine specification

### Basic parameter

Manufacturer	dongfeng Cummins
Model	QSZ13-G3
No. of cylinder	6
Type	4 cycle, Vertical In-line
Prime Power	450kw /603HP
Standby Power	500kw /670HP
Induction system	Turbocharged and Air to Air Aftercooled

Governor	ECU
Bore x Stroke	130x163mm

Displacement	13.0L
Compression ratio	17:1
Oil Capacity(Total)	75.33L
Coolant Capacity(Engine only)	23.1L
Cranking Motor Voltage	DC24V

### Fuel System

Type Injection system	Electronically controlled high voltage common rail
Min. Allowable flow of fuel to fuel pump	118.6 L/h

### Lubrication system

Oil Pressure	
---Idle speed	82.7kPa
---Rated speed	207-300kPa
Max. allowable oil temperature	121°C
Oil Pan capacity - Low/High	N /A
Total system capacity	75.33L

### Air induction system

Maximum allowable intake air restriction	
---with clean filter element	3.7kPa
---with dirty filter element	6.2kPa
Intake Air alarm temperature	85°C

### Exhaust system

Max. allowable back pressure	13kPa
Standard exhaust pipe diameter	130mm

### Cooling system

Coolant capacity	
---Engine only	23.1L
---Total system	73.1 L
---With heat exchanger	50L
Standard thermostat(modulating) range	82-95 °C
Minimum cap pressure	103kPa
Max. allowable top tank temperature for stand by/prime power	104/100 °C

### Electric system

Min. recommended battery capacity (24V)	
---10°C(50°F) & above- 0°F CCA	900
--- 0°C(32°F) to 10°C(50°F)- 0°F CCA	900
---18°C(0°F) to 0°C(32°F)- 0°F CCA	900
Max. allowable resistance of Starting circuit	0.002ohm
Starter(heave,Anode)	DC24V
Battery recharge system, negative ground	40ampere

## Alternator specification

Phases	3
Poles	4
Power factor(cosφ)	0.8
Winding connection	Star
Winding pitch	2/3
Voltage regulator type	AVR

Coating	Vacuum impregnation
Insulation class	H
Protection	IP23
Excitation system	Self-excited
Bearing	Single Bearing
Coupling	Flexible disc

## Control system Introduction

### Deepsea 6120 Auto start & auto mains failure control panel

**Deepsea 6120** is an auto mains failure controller for single generator, it can monitor and protect the generator working all the time. it has a LCD display which clearly shows the status of the engine. this controller include seven inputs and six outputs. This controller can also be programmed using the front panel or by using DSE configuration Suite PC software

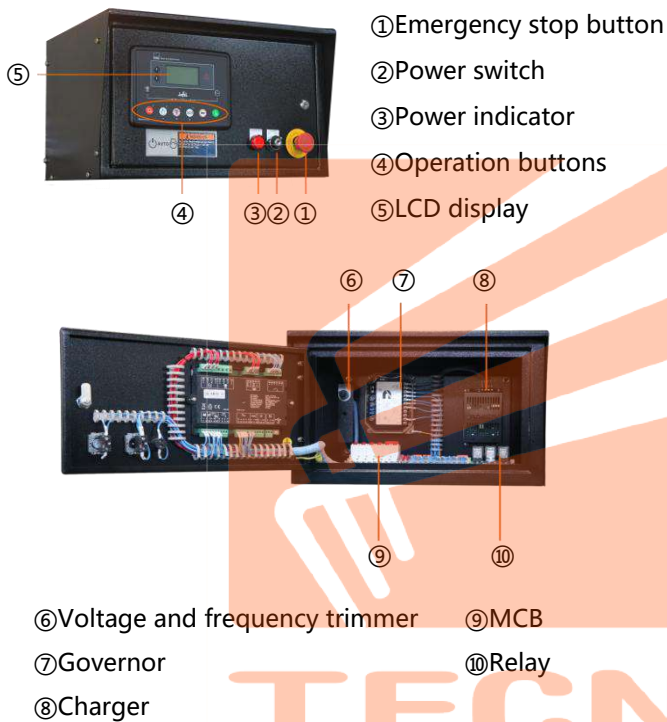

### Key Features:

- Auto start/stop, load transfer and alarming of generator
- Remote start on or off load
- With hierarchical loading function
- Multiple start/stop cycles can be preset
- 3 phase generator and mains voltage monitoring.
- Generator/load power detection(kW, kVA, kVA<sub>r</sub> PF)
- Overload protection (kW)
- Load current monitoring and protection
- Engine speed protection
- Engine pre-heat
- Engine start idle & stop idle
- Battery voltage monitoring
- Start under the low battery
- 4 active outputs
- 4 digital inputs and 3 analogue inputs.
- 6 Custom digital input
- 6 outputs(4 configurable on magnetic pick-up, 6 configurable on Canbus version)
- DSE2130,DSE2157,DSE2548 expansion module can be connected
- Support 0-10V or 4-20mA oil pressure sensor

### Main features:

- Multi language display
- Mains failure self starting
- The running time of the engine can be recorded to facilitate the maintenance and repair of the unit
- User-friendly set-up and button layout
- LCD display can display multiple parameters at the same time
- Support EFI engine
- IP65 rating (with optional gasket)
- PC and front panel configuration
- 100 event records
- Data recording and trend analysis

### Protection:

- Two sets of protection parameters can be preset
- Normal alarm, electrical trip and shutdown alarm can be set to effectively monitor the engine speed,oil pressure, water temperature and oil level, as well as the frequency, voltage, current and power of the alternator, for complete engine/alternator protection
- Low Oil Pressure
- High water Temperature
- High voltage and low voltage
- Overspeed
- Emergency stop
- Fail to start

# AOSIF Soundproof Canopy Introduction:

## Standard Type:

- |  |   |
|--|---|
| <ul style="list-style-type: none"> <li>● The arc angle structure makes the appearance beautiful and not easy to bump</li> <li>● High quality coating powder, chemical surface treatment &amp; 100-120um coating thickness greatly improving the anti-corrosion and anti rust level</li> <li>● Stainless steel hinge &amp; door lock are beautiful and anti-rust</li> <li>● 2.0mm cold rolled plate used makes the body more solid</li> <li>● The bottom forklift and loading port design enables easy loading and unloading</li> <li>● The drainage outlets are all connected to the outside for easy operation</li> </ul> | <ul style="list-style-type: none"> <li>● The sufficient air in &amp; out design ensure long-term and stable operation of the unit</li> <li>● Isolation net is designed for air inlet, exhaust outlet and muffler outlet to prevent objects from entering the unit</li> <li>● High density foam used inside effectively reduces noise</li> <li>● Ceiling Lighting is equipped for easy operation</li> <li>● The built-in base fuel tank with fuel filler set on the shell facilitates refueling</li> <li>● Models above medium power range are designed with top hoisting mechanism to facilitate transportation of the unit.</li> </ul> |
|--|---|

## Imitated container type:

- |  |  |
|--|--|
| <ul style="list-style-type: none"> <li>● The shell is made of 3.0mm hot rolled steel plate so as to withstand the lifting capacity of 15-ton without deformation</li> <li>● The switch cabinet and control panel are respectively set on both sides of the shell for easy maintenance &amp; operation</li> <li>● The shell looks similar to standard container, and can be loaded into 40HQ container for transportation, which is convenient for shipping</li> <li>● The lifting eye holes are designed on the top same as the standard container for easy handling</li> <li>● High density foam used inside effectively reduces noise</li> <li>● The built-in base fuel tank with fuel filler set on the shell facilitates refueling</li> <li>● Double emergency stop button set on different surfaces enables quick response to operation requirements</li> </ul> | <ul style="list-style-type: none"> <li>● The shell base is independent from the unit with 3mm thick checkered steel plate floor, which is beautiful &amp; antiskid, and is convenient for overhaul &amp; maintenance of the unit</li> <li>● The door handle, lock and hinge are all made of stainless steel to avoid rusting</li> <li>● The air out louver made of the mesh plate with podwer coating and pasted with high-density glass fiber is beautiful and not easy to rust, and can further reduce the noise</li> <li>● Isolation net is designed for air inlet, exhaust outlet and muffler outlet to prevent objects from entering the unit</li> <li>● The sufficient air in &amp; out design ensure long-term and stable operation of the unit</li> <li>● The drainage outlets are all connected to the outside for easy operation</li> <li>● Ceiling Lighting is equipped for easy operation</li> </ul> |
|--|--|

## Standard container type:

- |  |   |
|--|---|
| <ul style="list-style-type: none"> <li>● Can be shipped on board directly during transportation</li> <li>● The mesh plate with podwer coating and inner pasted with high-density glass fiber is installed inside the shell, which is beautiful and anti-rust, and can further reduce the noise</li> <li>● 3mm thick checkered steel plate floor is beautiful &amp; antiskid, and is convenient for overhaul &amp; maintenance of the unit</li> <li>● Double emergency stop button set on different surfaces enables quick response to operation requirements</li> <li>● The independent daily fuel tank can be designed to put inside to meet requirements of continuous operation</li> <li>● The fuel filler is set on the shell to facilitate refueling</li> </ul> | <ul style="list-style-type: none"> <li>● The switch cabinet and control panel are respectively set on both sides of the shell for easy maintenance &amp; operation</li> <li>● The air in &amp; out louver made of the mesh plate with podwer coating and pasted with high-density glass fiber is beautiful and not easy to rust, and can further reduce the noise</li> <li>● Isolation net is designed for air inlet, exhaust outlet and muffler outlet to prevent objects from entering the unit</li> <li>● The sufficient air in &amp; out design ensure long-term and stable operation of the unit</li> <li>● The drainage outlets are all connected to the outside for easy operation</li> <li>● Ceiling Lighting is equipped for easy operation</li> </ul> |
|--|---|

## Decomposition diagram introduction of AOSIF Typical Canopy



### Standard supply scope:

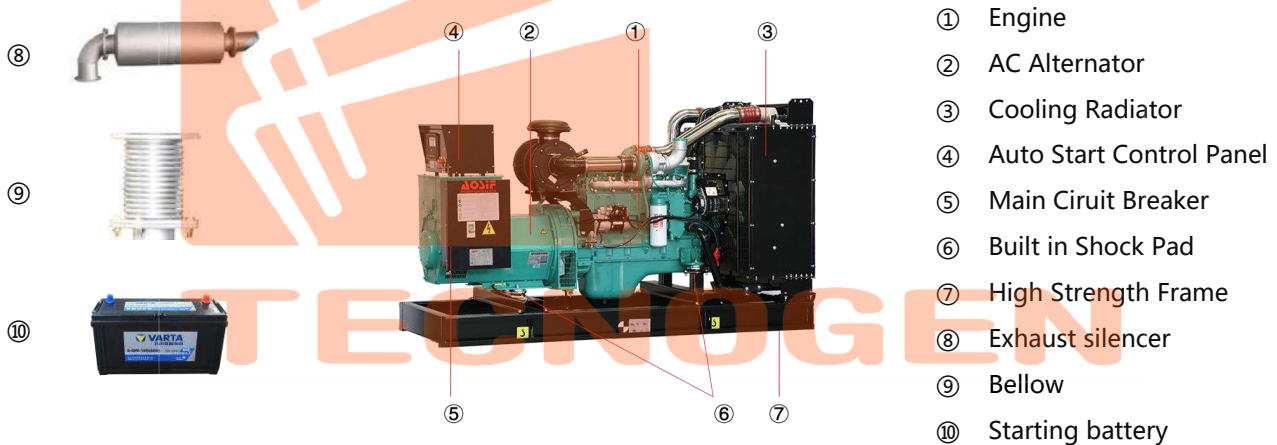

### Optional supply scope:

Genset	Engine	Alternator	Control system
<ul style="list-style-type: none"> <li>● Tool box</li> <li>● Base fuel tank</li> <li>● External daily fuel tank</li> <li>● Trailer</li> </ul>	<ul style="list-style-type: none"> <li>● Fuel heater</li> <li>● Fuel and water separator</li> </ul>	<ul style="list-style-type: none"> <li>● Temp. detector for winding and bearing</li> <li>● PMG</li> <li>● Antirust, mildew and salt fog treatment</li> <li>● Anti condensation heater</li> </ul>	<ul style="list-style-type: none"> <li>● ATS</li> <li>● Synchronization System</li> <li>● Adjustable earth relay</li> </ul>
Breaker	Fuel system	Lub-oil system	Cooling system
<ul style="list-style-type: none"> <li>● ABB</li> <li>● Schneider</li> </ul>	<ul style="list-style-type: none"> <li>● Low fuel level alarm</li> <li>● Auto Fuel Pump</li> <li>● T Valve</li> </ul>	<ul style="list-style-type: none"> <li>● Lub oil heater</li> <li>● Temp.-sensor</li> <li>● Oil drain Pump</li> </ul>	<ul style="list-style-type: none"> <li>● Elec.coolant Heater</li> </ul>

Contact your local distributor for more information:



**TECNOGEN**



[www.tecnogen.pe](http://www.tecnogen.pe)



[comercial@tecnogen.pe](mailto:comercial@tecnogen.pe)



[+ 51 986 364 537](tel:+51986364537)



[Jr. Ayacucho 226, Callao, Perú](#)

Follow us on:

