



TECNOGEN

PERKINS GENSETS SERIES

DATA SHEET AP438

350 KW STAND BY

320 KW PRIME



TECNO GENERACION SAC

Lima - Perú

General Performance Data

Prime Power	400KVA/320KW	Engine	Brand	Perkins
Stand by Power	438KVA/350KW		Model	2206C-E13TAG2
Frequency/Speed	60Hz/1800rpm	Control module	Deepsea 6120	
Rated Power Factor(cosφ)	0.8	Rated Current	1050A	
Standard Voltage	220V	Capacity of Breaker	1250A	
Phases	3	Starting Voltage	DC24V	

Fuel consumption

Rated output	Fuel consumption rate	
100%Standby	200g/KW.h	90L/h
100%Prime	204g/KW.h	84L/h
75%Prime	210g/KW.h	65L/h
50%Prime	220g/KW.h	46L/h
25%Prime		

Standards followed

ISO9001	ISO14001
ISO8528	ISO12100
ISO13849	EN12601
GB12786	GB/T2820
IEC60034	IEC60204
CE	RETIE

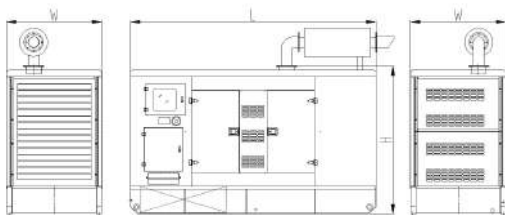
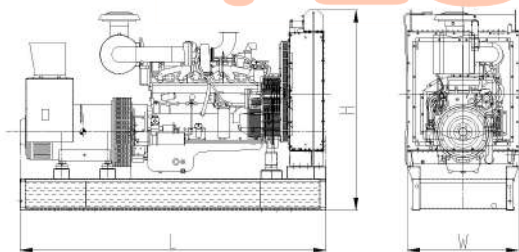

Dimensions and Weights

Type	Open	Silent
Length(mm)	3080	3800
Width(mm)	1140	1500
Height(mm)	2080	2230
Weight(kg)	3200	4140
Base fuel tank volume (L)	600	600

Engine specification

Basic parameter

Manufacturer	Perkins
Model	2206C-E13TAG2
No. of cylinder	6
Type	4 stroke Vertical In-line
Prime Power	373.4kw /508HP
Standby Power	406.5kw /553HP
Induction system	Turbocharged, air-to-air charge cooling
Governor	Electronic
Bore x Stroke	130x157mm

Displacement	12.5L
Compression ratio	16.3:1
Oil Capacity(Total)	40L
Coolant Capacity(Engine only)	51.4L
Cranking Motor Voltage	DC24V

Fuel System

Type Injection system	MEUI
Min. Allowable flow of fuel to fuel pump	90L/h

Lubrication system

Oil Pressure	
---Idle speed	358kPa
---Rated speed	Min 270kPa
Max. allowable oil temperature	113°C
Oil Pan capacity - Low/High	32.5L/38L
Total system capacity	40L
Angularity of oil pan-Front Down	7°

Air induction system

Maximum allowable intake air restriction	
---with clean filter element	2.5kPa
---with dirty filter element	6.4kPa
---air filter type	Paper element

Exhaust system

Max. allowable back pressure	10.0kPa
Standard exhaust pipe diameter	123mm

Cooling system

Coolant capacity	
---Engine only	-
---Total system	51.4L
---With heat exchanger	-
Standard thermostat(modulating) range	87-98 °C
Max. coolant temperature	-
Max. allowable top tank temperature for stand by/prime power	104 °C

Electric system

Min. recommended battery capacity (12V)	
---10°C(50°F) & above- 0°F CCA	588A
--- 0°C(32°F) to 10°C(50°F)- 0°F CCA	588A
---18°C(0°F) to 0°C(32°F)- 0°F CCA	828A
Minimum cranking speed	106rpm
Starter(heave,Anode)	DC24V
Battery recharge system, negative ground	70ampere

Alternator specification

Phases	3
Poles	4
Power factor(cosφ)	0.8
Winding connection	Star
Winding pitch	2/3
Voltage regulator type	AVR

Coating	Vacuum impregnation
Insulation class	H
Protection	IP23
Excitation system	Self-excited
Bearing	Single Bearing
Coupling	Flexible disc

Control system Introduction

Deepsea 6120 Auto start & auto mains failure control panel

Deepsea 6120 is an auto mains failure controller for single generator, it can monitor and protect the generator working all the time. it has a LCD display which clearly shows the status of the engine. this controller include seven inputs and six outputs. This controller can also be programmed using the front panel or by using DSE configuration Suite PC software

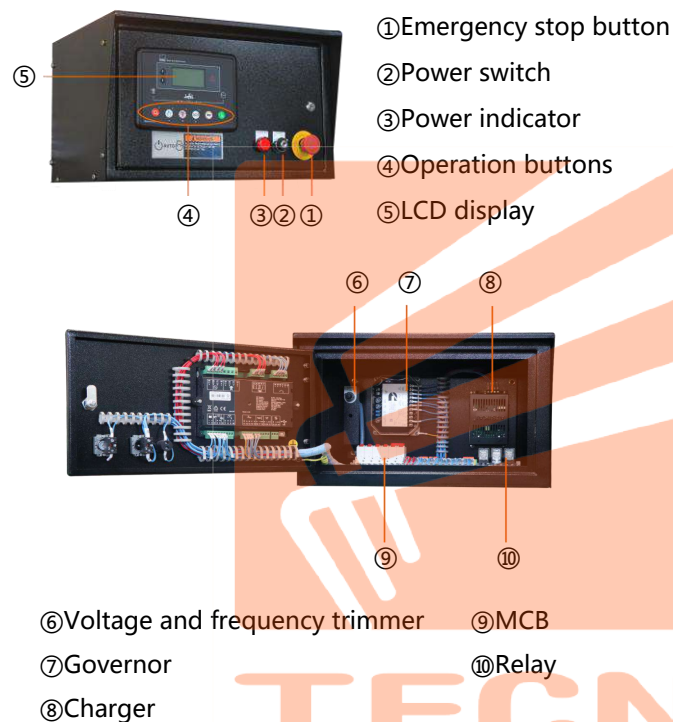

Key Features:

- Auto start/stop, load transfer and alarming of generator
- Remote start on or off load
- With hierarchical loading function
- Multiple start/stop cycles can be preset
- 3 phase generator and mains voltage monitoring.
- Generator/load power detection(kW, kVA, kVA_r PF)
- Overload protection (kW)
- Load current monitoring and protection
- Engine speed protection
- Engine pre-heat
- Engine start idle & stop idle
- Battery voltage monitoring
- Start under the low battery
- 4 active outputs
- 4 digital inputs and 3 analogue inputs.
- 6 Custom digital input
- 6 outputs(4 configurable on magnetic pick-up, 6 configurable on Canbus version)
- DSE2130,DSE2157,DSE2548 expansion module can be connected
- Support 0-10V or 4-20mA oil pressure sensor

Main features:

- Multi language display
- Mains failure self starting
- The running time of the engine can be recorded to facilitate the maintenance and repair of the unit
- User-friendly set-up and button layout
- LCD display can display multiple parameters at the same time
- Support EFI engine
- IP65 rating (with optional gasket)
- PC and front panel configuration
- 100 event records
- Data recording and trend analysis

Protection:

- Two sets of protection parameters can be preset
- Normal alarm, electrical trip and shutdown alarm can be set to effectively monitor the engine speed,oil pressure, water temperature and oil level, as well as the frequency, voltage, current and power of the alternator, for complete engine/alternator protection
- Low Oil Pressure
- High water Temperature
- High voltage and low voltage
- Overspeed
- Emergency stop
- Fail to start

Decomposition diagram introduction of AOSIF Typical Canopy



Standard supply scope:

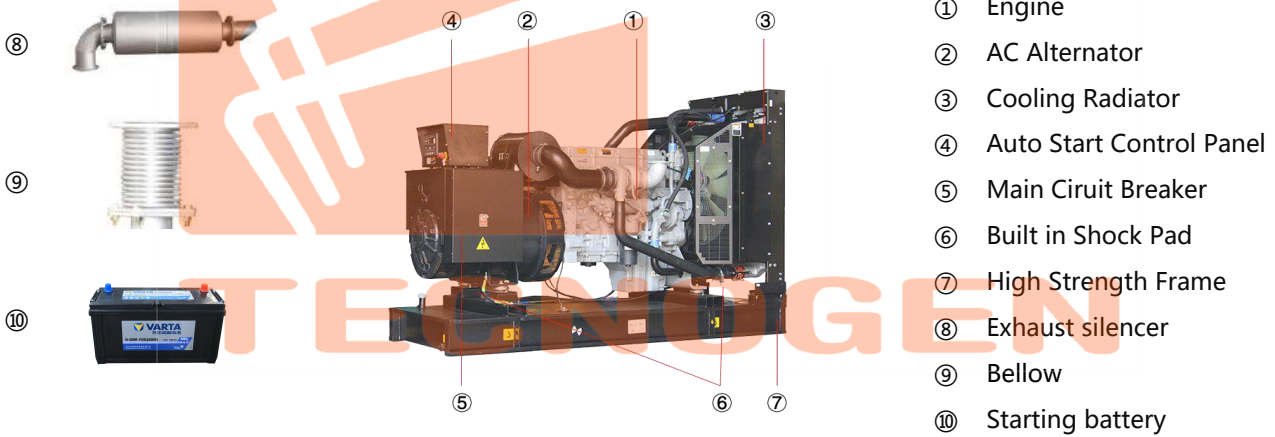

Optional supply scope:

Genset	Engine	Alternator	Control system
<ul style="list-style-type: none"> ● Tool box ● Base fuel tank ● External daily fuel tank ● Trailer 	<ul style="list-style-type: none"> ● Fuel heater ● Fuel and water separator 	<ul style="list-style-type: none"> ● Temp. detector for winding and bearing ● PMG ● Antirust, mildew and salt fog treatment ● Anti condensation heater 	<ul style="list-style-type: none"> ● ATS ● Synchronization System ● Adjustable earth relay
Breaker	Fuel system	Lub-oil system	Cooling system
<ul style="list-style-type: none"> ● ABB ● Schneider 	<ul style="list-style-type: none"> ● Low fuel level alarm ● Auto Fuel Pump ● T Valve 	<ul style="list-style-type: none"> ● Lub oil heater ● Temp.-sensor ● Oil drain Pump 	<ul style="list-style-type: none"> ● Elec.coolant Heater

Contact your local distributor for more information:



TECNOGEN



www.tecnogen.pe



comercial@tecnogen.pe



[+ 51 986 364 537](tel:+51986364537)



[Jr. Ayacucho 226, Callao, Perú](#)

Follow us on:

